

CAPACITY	SYMBOL/ SERIAL NO.	CIRCUIT DIAGRAM
AC 230V		
65W x 1		

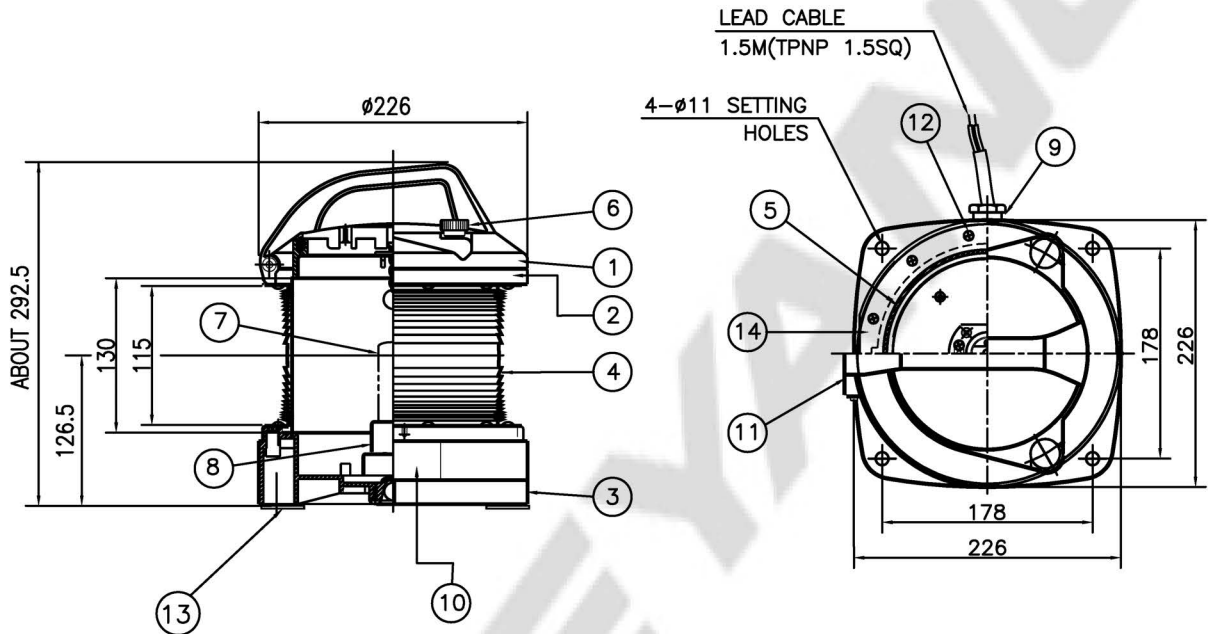

**NOTE**

1. APPLICATION RANGE : VESSEL OF 50M IN LENGTH AND ABOVE
2. MINIMUM VISIBILITY : 5 N.M

**\* CAUTION!!**  
Do not install the navigation light upside down.  
Since breathing device is installed on the bottom of fixture.

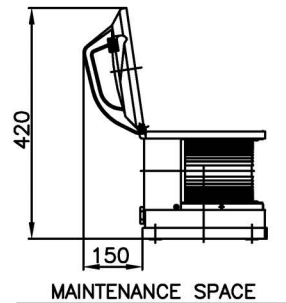

					7	NAVIGATION LIGHT LAMP	-	1	P28s
13	ANTI-VIBRATION PACKING	C.R.	4	5mm	6	CLAMP BOLT	BRASS	2	
12	T/H TAPPING SCREW	STAINLESS STEEL 304	24	M4	5	GASKET	SILICONE RUBBER	1	
11	HINGE	POLYCAR-BONATE	1		4	LENS	POLYCAR-BONATE	1	CLEAR
10	NAME PLATE	STAINLESS STEEL 316L	1		3	BODY	POLYCAR-BONATE	1	
9	CABLE GLAND(#20)	NYLON	1	ø12~ø15	2	TOPPER	POLYCAR-BONATE	1	
8	LAMP HOLDER	PPS	1	P28s	1	COVER	POLYCAR-BONATE	1	
NO	NAME OF PARTS	MATERIAL	Q'TY	REMARKS	NO	NAME OF PARTS	MATERIAL	Q'TY	REMARKS

APPROVED	B. K. KIM	UNIT	MM	TITLE;  MANOEUVRING LIGHT FOR MARINE USE	
CHECKED		SCALE	N/S		
DRAWING	B. I. KIM	COLOR	MAT BLACK		
DATE	2015.12.04	IP	56		
MODEL NO.		MVP-SW6523Hh-1.5M-MED		WEIGHT	2.9 Kg
DWG NO.		L32060105		SHEET NO.	29